

**ROKKER™ XT Series
Dual 7.25" Sub-Woofer Speaker
Kit for Harley Saddlebags**

#HSWR-7252-XTC

**Installation
Instructions**

Installation Instructions

1. Remove both left and right saddlebag lids and latch assemblies from the saddlebags.
2. Remove both saddlebags, side covers, seat and fuel tank.
3. Carefully position the provided drill template onto the left saddlebag and tape it down securely. **Diagram A**

4. Using a sharp awl or center-punch, carefully punch mark the saddlebag in the locations indicated on the template.

5. Remove the template and using a 5/32" drill bit, carefully drill holes in the indicated locations.

6. Using the previously drilled 5/32" center hole as a pilot hole, cut a hole in the saddlebag using a 4 3/4" hole saw. **Diagram B**

7. Carefully drill a 5/16" diameter hole in the bottom of the left saddlebag in the location shown. **Diagram C**

8. Install the provided rubber grommet into the hole. Then, from the inside of the saddlebag, route the left side speaker harness (brown/white-brown) through the grommet and install the provided plastic connector onto the speaker harness. **IMPORTANT: BE SURE TO INSERT THE CORRECT WIRES INTO THE CORRECT LOCATION IN THE PLASTIC CONNECTOR.** **Diagram D**

9. Using the hardware provided, install the speaker grill and the speaker adapter into the saddlebag. **Note:** The speaker ring adapter should be installed with the word "TOP" facing up. **Diagram E**

10. Connect the wire terminal spades to the correct terminals of the J&M 7.25 subwoofer speaker.

11. Install the J&M subwoofer speaker and the protective cowl onto the speaker adapter using the (4) provided self threading screws. **Note:** The speaker terminals should be facing down and the open area of the protective cowl should face the bottom rear corner of the saddlebag.

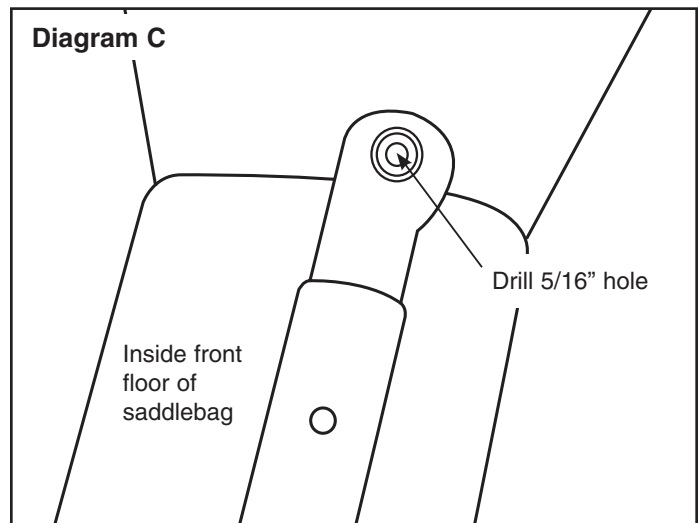
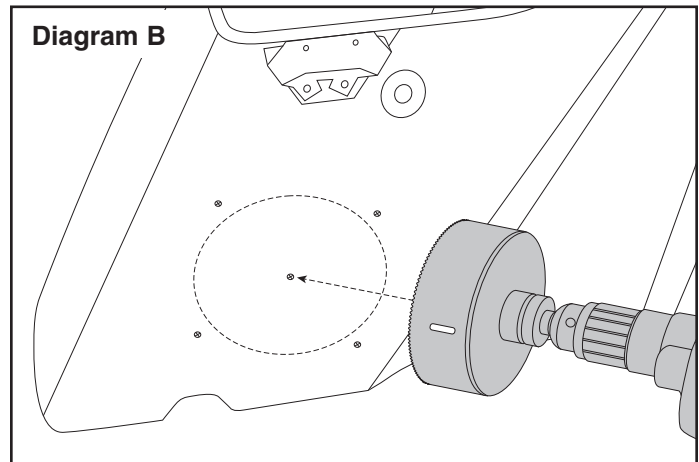
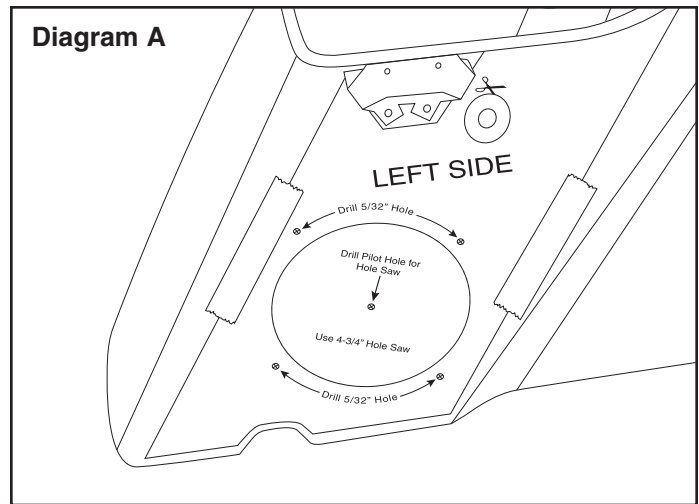

12. Re-install the saddlebag lid and install the saddlebag assembly onto the motorcycle.

13. Connect the forward section of the speaker harness to the completed saddlebag assembly and route the harness along the frame, under the fuel tank, and into the fairing. Secure the harness using the provided tie-straps.

14. Repeat the entire process for the right side saddlebag assembly.

15. Reinstall the fuel tank, seat, and side covers.

16. Refer to your amplifier installation manual for proper adjustments for Low Frequency Subwoofer speakers.

17. Excessively high Gain and/or Bass-Boost settings can overheat or cause permanent damage to your J&M ROKKER Subwoofers. This type of damage is not covered under the J&M speaker warranty.

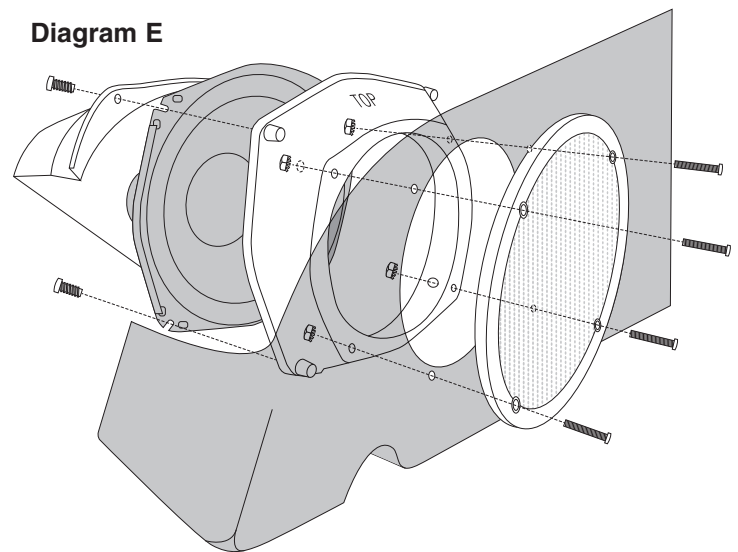
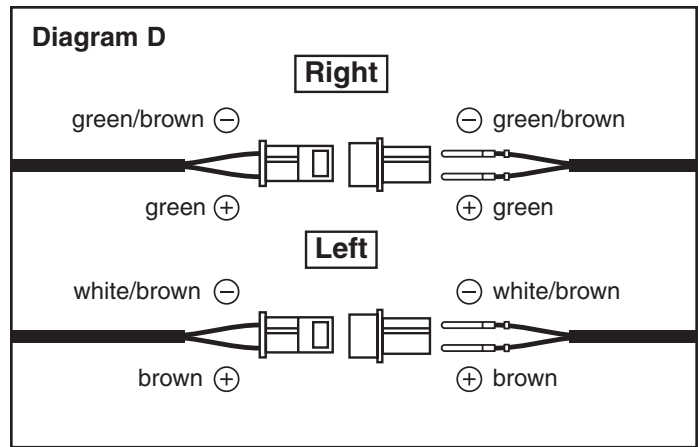

WARRANTY AND REPAIR INFORMATION

TWO YEAR LIMITED WARRANTY In order to facilitate the servicing of this warranty, the Warranty Registration Form should be filled out and returned within 10 days of the date of purchase. However, return of the Warranty Registration Form is not a precondition of this warranty, and this Warranty will be observed by **J&M CORPORATION** whether or not the Warranty Registration Form is returned, on the condition that other satisfactory evidence of the date of the original purchase is provided to **J&M CORPORATION**.

WHO PROVIDES THE WARRANTY? This warranty is provided by **J&M CORPORATION**.

WHO IS PROTECTED? This warranty is extended only to the original owner of this J&M CORPORATION product and may not be transferred or assigned.

WHAT IS COVERED AND HOW LONG? This warranty covers all defects in material or workmanship of our product for a period of 2 years from date of original retail purchase. At its option, **J&M CORPORATION** will repair or replace any defective part(s) or equipment.

The provisions of the warranty shall not apply to any unit which has been subjected to misuse, neglect, incorrect mechanical or electrical installation, unauthorized modifications, accident, nor to units which have been repaired or altered outside of our factory.

PROCEDURE FOR OBTAINING PERFORMANCE OF WARRANTY In the event that the product does not conform to this warranty, the product should be shipped prepaid to the **J&M CORPORATION** service facility. Transportation charges, insurance fees, and labor costs for shipment, removal, or reinstallation of our product are not covered by this warranty. Loss or damage in shipment is the sole responsibility of the freight carrier.

FOR YOUR INFORMATION Repair as provided under this warranty is the exclusive remedy of the consumer. **J&M CORPORATION** shall not be liable for any incidental or consequential damages or for breach of any express or implied warranty on this product. Except to the extent prohibited by applicable law, any implied warranty of merchantability or fitness for a particular purpose on this product is limited in duration to the duration of the warranty. Some states do not allow the exclusion or limitation of incidental or consequential damages, or allow limitations on how long an implied warranty lasts, so the above limitations or exclusion may not apply to you. This warranty gives you specific legal rights which vary from state to state.

J&M CORPORATION reserves the right to make changes in design and to make improvements in its products without the obligation to incorporate the changes or improvements in any of its previously manufactured products.

J&M CORPORATION has not authorized anyone to make representations or warranties other than the warranty contained herein.

The above warranty is effective for all products manufactured after 10/01/86.

NON-WARRANTY REPAIR RATES **J&M CORPORATION** reserves the right to change the labor repair rates without prior notice. At the time of this printing the out-of-warranty repair is \$40 per hour for labor only. However, the customer is advised to verify the current rate when he/she calls customer service to obtain the return authorization number.

FACTORY SERVICE ADDRESS J&M Corporation, 1415 S. Cherry Avenue, Tucson, Arizona, 85713, U.S.A. Tel: 1-800-358-0881 audio@jmc Corp.com www.jmcorp.com

CUSTOMER SERVICE NUMBER 1-800-358-0881



J&M Corporation
Tucson, Arizona, U.S.A.
Tel. 1-800-358-0881
www.jmcorp.com
audio@jmc Corp.com

Thank you for the confidence you have shown in J & M by purchasing one of our innovative products. It will give you many hours of riding pleasure. If you have any questions during installation or require more information about this product, you may call our Customer service Department (English only, please) at 1-800-358-0881, Monday through Friday, 8:00 a.m. to 5:00 p.m. Mountain Standard Time, U.S.A.



WARRANTY REGISTRATION FORM Please fill out this card completely and mail it immediately after purchase. Please be sure that your zip code and serial number (if applicable) are legible. This will help us to serve you better.

(PLEASE PRINT)

Name _____

Address _____

City _____ State _____ Zip _____

Motorcycle Other E-mail _____

Make _____ Model _____ Year _____

Product part number _____

Serial number (if applicable) _____

Date of purchase _____

Name of dealer it was purchased from _____



Mail to:
J&M Corporation
1415 S. Cherry Avenue
Tucson, AZ 85713
U.S.A.